



RM8 24D

### Features

- 8 Nm torque to regulate dampers up to approx. 1.6 m<sup>2</sup>
- Control signal on/off or 3-point
- Power supply 24 Vac and 230 Vac
- Running time 156 sec.
- Suitable shaft dimensions  
Max. 13 mm  
Min. 10 mm
- Position indicator
- Angle of rotation changeable from outside
- Direction changeable via wiring diagram
- On request  
2 Nm torque (running time 72 seconds)  
4 Nm torque (running time 108 seconds)  
6 Nm torque (running time 108 seconds)
- On request  
1 auxiliary switch  
2 auxiliary switches

### Technical data

<b>Torque</b>	8 Nm
<b>Power supply</b>	24 Vac +/-10% 230 Vac +/-10% (50/60 Hz)
<b>Control signals</b>	on/off or 3-point
<b>Running time</b>	156 sec.
<b>Position indicator</b>	Mechanical indication
<b>Angle of rotation</b>	Max. 95° (changeable from outside)
<b>Direction of rotation</b>	Via wiring diagram
<b>Power consumptions</b>	3.0 VA for 24 Vac 6.0 VA for 230 Vac
<b>Noise level</b>	Max. 45dB(A)
<b>Connection</b>	Via terminals 0.5 mm <sup>2</sup> to 1.5 mm <sup>2</sup>
<b>Protection</b>	IP42
<b>Ambient temperature</b>	-5 to +50°C
<b>Storage temperature</b>	-30 to +70°C
<b>Usage life</b>	>60000 times
<b>Maintenance</b>	Maintenance free
<b>CE</b>	approved
<b>Weight</b>	760 g

### Ordering

Type no.	Description			
<b>Damper actuator</b>				
<b>RM8 24D</b>	8 Nm	on/off or 3-point	24 Vac	156 sec.
<b>RM8 230D</b>	8 Nm	on/off or 3-point	230 Vac	156 sec.

## Description

RM on/off type damper actuator uses bi-directional motor.

### High dependable performance

RM8 on/off type damper actuator uses bi-directional magnetic clutch synchronous motor. It has overload protection function, and does not need limiter switch. The actuator will stop automatically, because the motor is clutched when it is operating to the end. And the damper actuator has a better precision adjustable mechanical limiter, and 1~2 auxiliary switches can be selected for optional.

Adjustable limiter with precision of 15°.

Optional overtime protection for longer motor life.  
1 or 2 optional auxiliary switch(es), the function of which can be made by order. The operational angle of the damper actuator which has 2 limitators can be adjusted by setting the peak turnplate. The adjustable feedback position is larger than 60° on clockwise, and small than 30° on anti-clockwise. Please find the installation details at Fig.4. The default setting of one switch type is at 90°, and that of two switches type is at 0° and 90°.

The 24 volt DC self-setting function is only for 24 volt AC damper actuator. It can supply enough power to let the damper actuator go back to 0°, when power supply is suddenly cut off.

### Simple and convenient function testing

It is also convenient to test the function of damper operation: push the manual button on the actuator, the gears inside the actuator will break away. The damper can be operated manually as keeping push the manual button.  
PLEASE DO NOT OPERATE WHEN POWER IS ON!

### Installation and connection details

All connections to BEMS controllers, data recorders etc. should be made using screened cable.

Normally the screen should be earthed at one end only (usually the controller end) to avoid earth hum loops which can create noise.

Low voltage signal and supply cables should be routed separately from high voltage or mains cabling.

Separate conduit or cable trays should be used.

Where possible, the controller's earth should be connected to a FUNCTIONAL EARTH, rather than the mains safety earth. This will provide better immunity to high frequency noise. Most modern buildings have a separate earth from this purpose.

All system wiring must be in compliance with all applicable

## Wiring

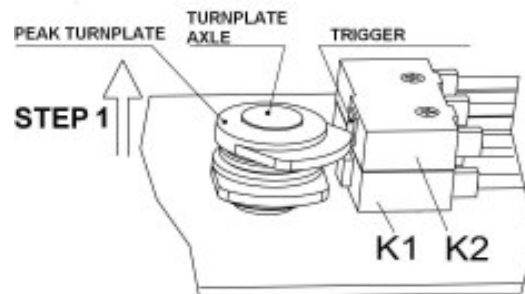
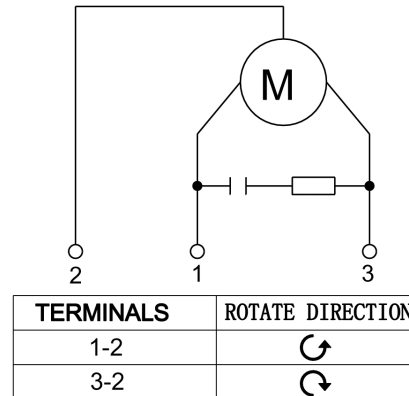



Fig.4

### TESTING STEPS:

1. Take the peak turnplate out.
2. Turn the axle to the needed position, then put the peak turnplate back, make sure the peak is just against the trigger. (As Fig.4)

 DO NOT OPERATE WHEN POWER IS ON!

**Dimensions**

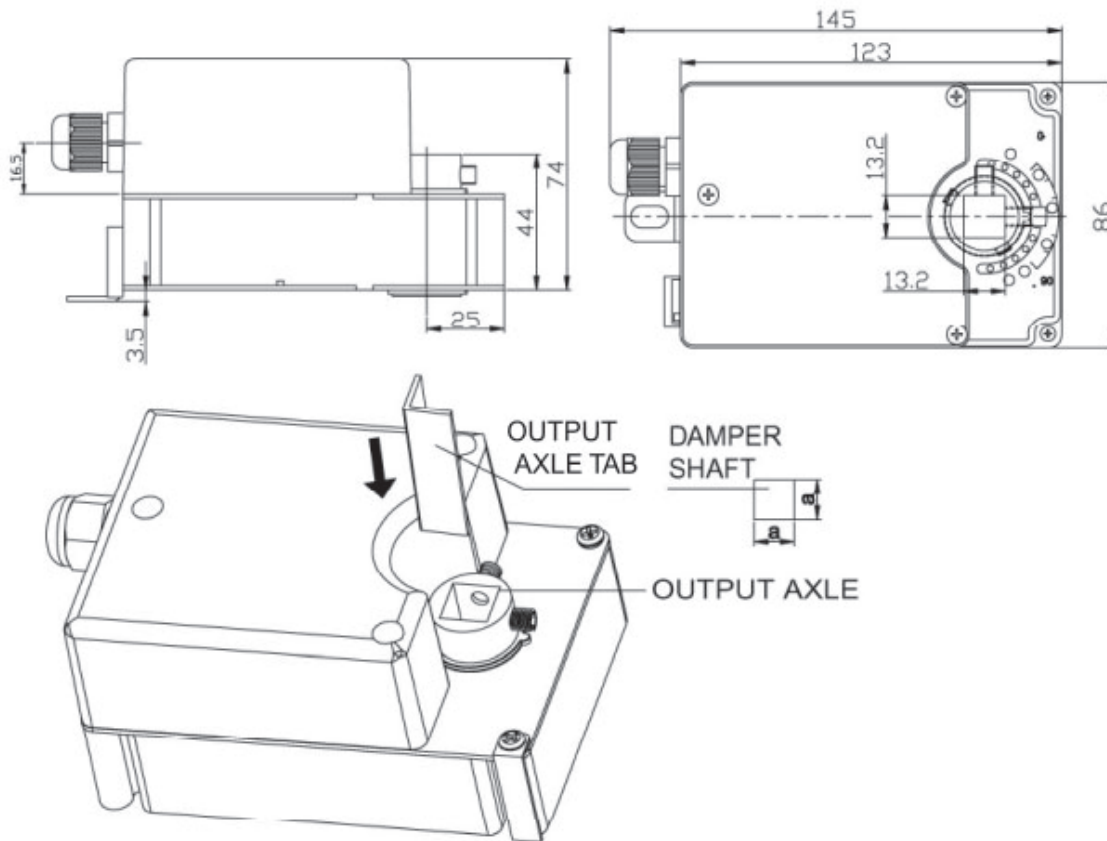

**Accessories supplied to the damper actuator**

2 limitative baffles, 2 baffle setscrews (M3x6), 1 actuator body setscrews (ST4.8X12.5) and 1 aluminium gasket (output axle tab).

**Damper shaft dimensions**

Max shaft dimension is 13 mm.

Min. shaft dimension is 10 mm when the output axle tab is used.

We reserve the right to make changes in our products without any notice which may effect the accuracy of the information contained in this leaflet.



RM8 24V

### Technical data

<b>Torque</b>	8 Nm
<b>Power supply</b>	24 Vac +/-10% (50/60 Hz)
<b>Control signal(s)</b>	0-10 Vdc for RM8 24V 2-10 Vdc or 4-20 mA for RM8 24VC (jumper selectable for RM8 24VC)
<b>Running time</b>	156 sec.
<b>Position indicator</b>	Mechanical indication
<b>Angle of rotation</b>	Max. 95° (changeable from outside)
<b>Direction of rotation</b>	Changeable via jumpers on pcb
<b>Power consumptions</b>	4.0 VA when operating
<b>Position precision</b>	+/- 5%
<b>Noise level</b>	Max. 45dB(A)
<b>Connection</b>	Via terminals 0.5 mm <sup>2</sup> to 1.5 mm <sup>2</sup>
<b>Protection</b>	IP 42
<b>Ambient temperature</b>	-5 to +50 °C
<b>Storage temperature</b>	-30 to +70 °C
<b>Usage life</b>	>60000 times
<b>Maintenance</b>	Maintenance free
<b>CE</b>	approved
<b>Weight</b>	760 g

### Features

- 8 Nm torque to regulate dampers up to approx. 1.6 m<sup>2</sup>
- Analogue control signal  
0-10 Vdc for RM8 24V  
2-10 Vdc or 4-20 mA (jumper selectable) for RM8 24VC
- Power supply 24 Vac
- Running time 156 seconds
- Suitable shaft dimensions  
Max. 13 mm  
Min. 10 mm
- Position indicator
- Angle of rotation changeable from outside
- Direction changeable via jumpers on pcb
- On request  
2 Nm torque (running time 72 seconds)  
4 Nm torque (running time 108 seconds)  
6 Nm torque (running time 108 seconds)

### Ordering

Type no.	Description				
<b>Damper actuator</b>					
<b>RM8 24V</b>	8Nm	0-10 Vdc	24 Vac	156 sec.	
<b>RM8 24VC</b>	8Nm	2-10 Vdc/4-20 mA	24 Vac	156 sec.	

**Control signals**

RM8 24V with 0-10Vdc control signal, the setting position of jumper J3 must be at point V (factory setting)

RM8 24VC with 0-10Vdc or 4-20 mA selectable control signal position of jumper J3 to be at point V for 2-10 Vdc control signal. position of jumper J3 to be at point A for 4-20 mA control signal.

**Simple installation**

Fix with square damper shaft.  
Damper shaft dimensions see Dimensions next page.  
The rotating angle of the actuator can be set by internal potentiometer (PT1). The match between working range and feedback signal is automatically done by the actuator.

**Manual operation**

It can be operated manually if needed:  
push the manual button on the actuator, the gearings inside the actuator will break away. The damper can be operated manually when keep pushing the manual button.  
Please do not operate when power on.

**High dependable performance**

RM8 24V and RM8 24VC damper actuators uses bi-directional magnetic clutch synchronous motor. It has overload protection and overtime protection, and no need limiter needed, the actuator will stop automatically when it runs to the end. And the damper actuator has a precision of 15° adjustable mechanical limiter.

**Installation and connection details**

All connections to BEMS controllers, data recorders etc. should be made using screened cable.

Normally the screen should be earthed at one end only (usually the controller end) to avoid earth hum loops which can create noise.

Low voltage signal and supply cables should be routed separately from high voltage or mains cabling.

Separate conduit or cable trays should be used.

Where possible, the controller's earth should be connected to a FUNCTIONAL EARTH, rather than the mains safety earth. This will provide better immunity to high frequency noise. Most modern buildings have a separate earth from this purpose.

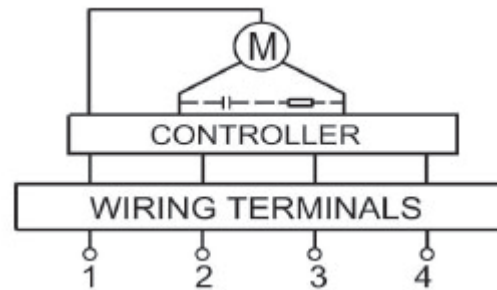

All system wiring must be in compliance with all applicable local and national codes.

**Wiring**



1. Power supply 24 Vac
2. COM
3. Control signal  
0-10 Vdc for RM8 24V  
2-10 Vdc or 4-20 mA for RM8 24VC
4. Feedback signal 0-10 Vdc

As power supply is 24 Vac, also the wiring for 4-20 mA is 3-wires.

INPUT CONTROL SIGNAL		ROTATE DIRECTION
DA	RA	
INCREASING	DECREASING	
DECREASING	INCREASING	

**PCB setting diagram**

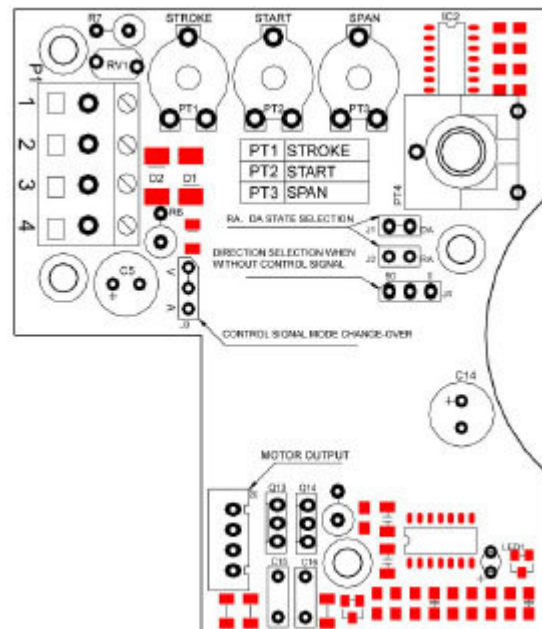

**Dimensions**

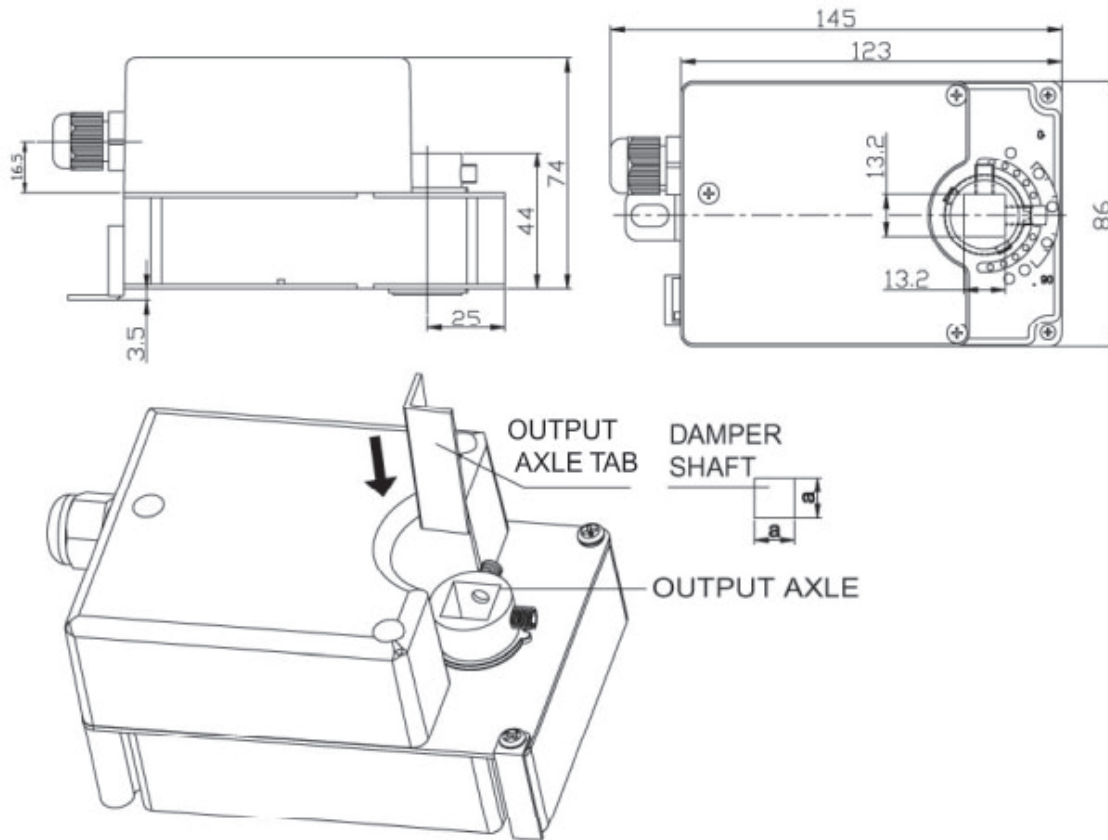

**Accessories supplied to the damper actuator**

2 limitative baffles, 2 baffle setscrews (M3x6), 1 actuator body setscrews (ST4.8X12.5) and 1 aluminium gasket (output axle tab).

**Damper shaft dimensions**

Max shaft dimension is 13 mm.

Min. shaft dimension is 10 mm when the output axle tab is used.

We reserve the right to make changes in our products without any notice which may effect the accuracy of the information contained in this leaflet.